



6" SUBMERSIBLE PUMPSET

MANUAL FOR INSTALLATION & OPERATION

(ECON SERIES)



AQUASUB ENGINEERING

THUDIYALUR POST, COIMBATORE - 641 034.

TEL : 0422 - 2642484, E-mail : marketing@aquagroup.in

Website : www.aquagroup.in

Dear Customer,

Please follow the instructions given in this manual to install and maintain our submersible pumpset to get reliable operation.

When you order spare parts in future, please inform the name plate details, viz., serial number, motor type, pump type and other data. Spare parts list of the pumpset is given at the end of this manual for your reference.

This submersible pumpset should be installed by technically qualified personnel in compliance with national and local electrical codes and as per our instructions in order to avoid electrical shock, unsatisfactory performance and equipment failure.

INDEX

1)	Motor	5
2)	Pump	5
3)	Receiving the Material	5
4)	Filling The Motor	6
5)	Arrangement For Erection	7
6)	Coupling Of Motor And Pump	8
7)	Electrical Installation	9
8)	Types of Installation	12
9)	Operation of Pump	15
10)	Operating Troubles and Causes	19

SPARE PARTS LIST AND SECTIONAL VIEW

1)	6” Submersible Motor - Econ	16
2)	6” Radial flow submersible Pump - Econ	17
3)	6” Mixed flow submersible Pump - Econ	18

1) Motor

The 'Texmo' wet type submersible motor is a squirrel cage induction motor completely filled with clear cold water. It features water lubricated thrust and journal bearings and a water-cooled winding of plastic coated waterproof winding wire. Since sand and other foreign particles can damage the motor it is protected by lip seal rings and a sand guard. Being sealed, excessive pressure can be developed inside the motor due to the thermal expansion of filled water during operation. This pressure is compensated by rubber diaphragm in the lower part of the motor.

2) Pump

The 'Texmo' pump is designed for pumping clear cold water with maximum permissible sand content of 50-grams in 1000 litres. It is of multistage construction with radial or mixed flow impellers and diffusers.

A strainer made of stainless steel is wrapped around the inlet bracket to restrict the entry of the stone pebbles.

3) Receiving the Materials

Motor and pump are packed in separate cases. When the cases are opened the nameplate details of both motor and pump are to be noted for future reference.

CAUTION



The Pump and Motor have water lubricated plain bearings and must therefore never run dry. Even starting the motor for a short period out of water must be strictly avoided, as it will cause damage to the bearings.

4) Filling the Motor

Position the motor vertically on its base. The two drain plugs provided at the top of the motor are removed. The motor is filled completely with water using the funnel. The drain plug at the bottom of the motor is then opened and the water is allowed to escape. After draining the motor completely, the drain plug at the bottom is fixed securely. The motor is then filled for a second time until water flows out of the open outlet plug at the top. Trapped air bubbles are removed by a gentle 'to and fro' rocking of the motor. After about 10 minutes, more water is poured to fill the loss of the volume caused by the escape of the air bubbles. The two plugs are refixed ensuring all the time that no water escaped. The motor is to be checked thoroughly for leakage of water before it is installed.

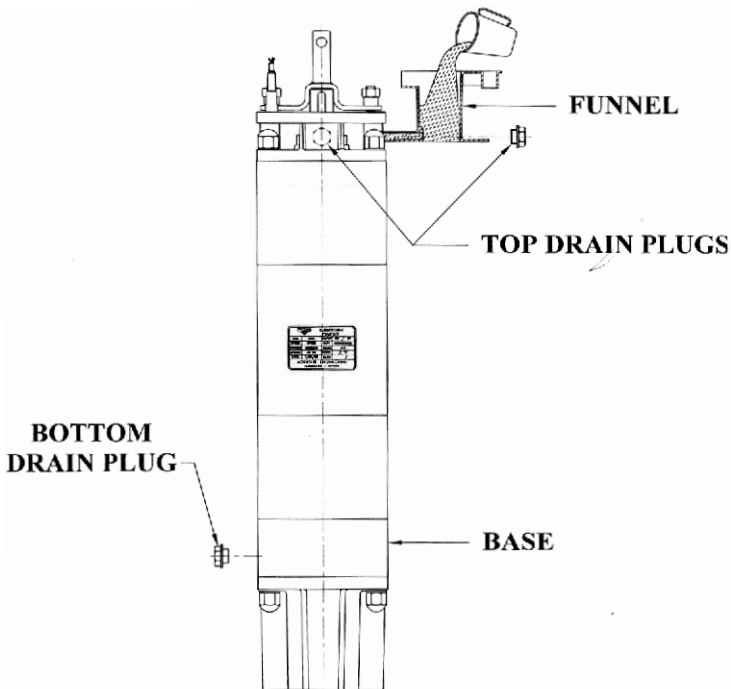

IMPORTANT : Only Clear cold drinking water is to be used.

5) Arrangement for Erection

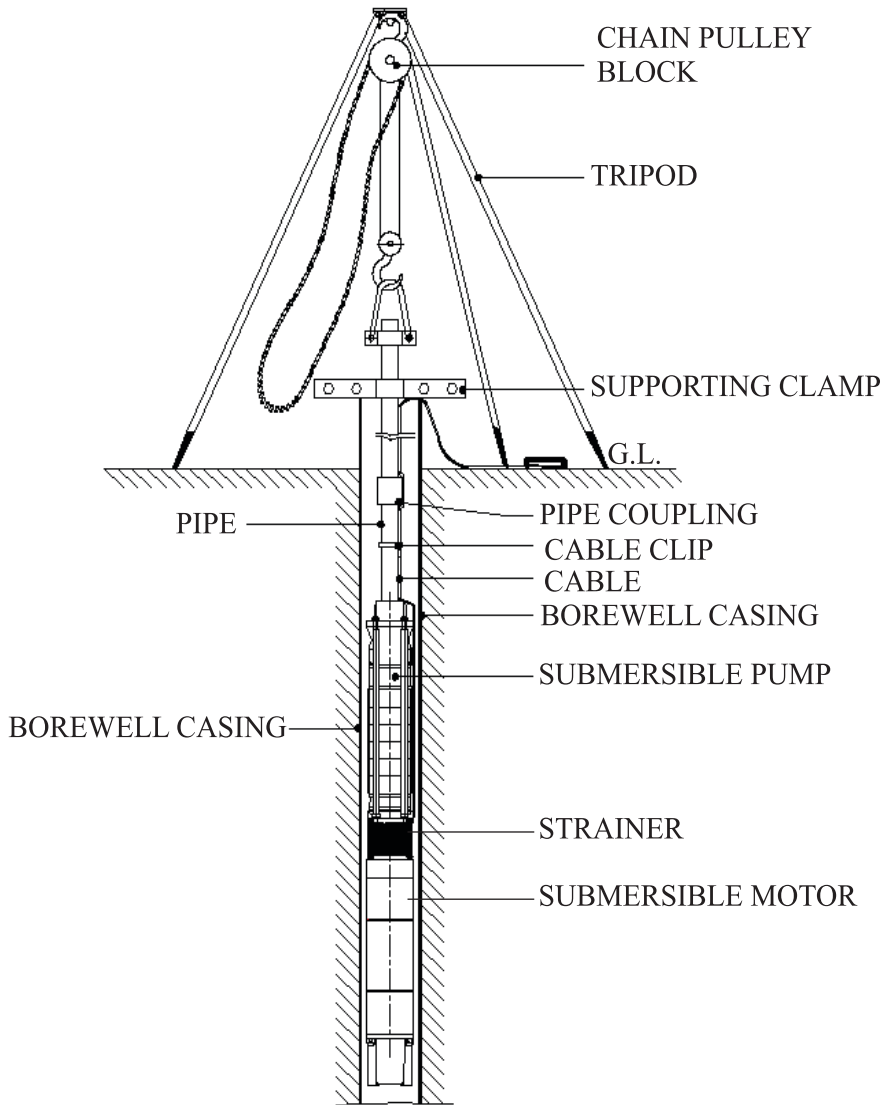

6) Coupling of Motor and Pump

To couple the motor and pump the following procedure can be adopted. The tripod is erected and the chain block is fixed in such a way that the hook and the center of the bore-well are in alignment. The motor is placed vertically close to the bore-well, the pump is taken out of the package and the cable guard and strainer is removed.

Threading compound is applied to the threaded portion at top of the pump, and to the threaded portion of a short length of pipe (Approximately 1 meter). This short length pipe is then screwed to the pump. The supporting clamp is fitted to the delivery pipe and the pump is suspended using chain block. The coupling is provided on the motor shaft. The pump is lifted and lowered carefully on the motor ensuring that the pump shaft is inserted into the coupling. The studs on the motor side should pass through the holes in the bottom of the inlet bracket. Ensure that the face of the inlet bracket rests on the top of the motor seating face. Now check the play by lifting the pump shaft, which should be 1mm. The cable guard and strainer are now fitted.

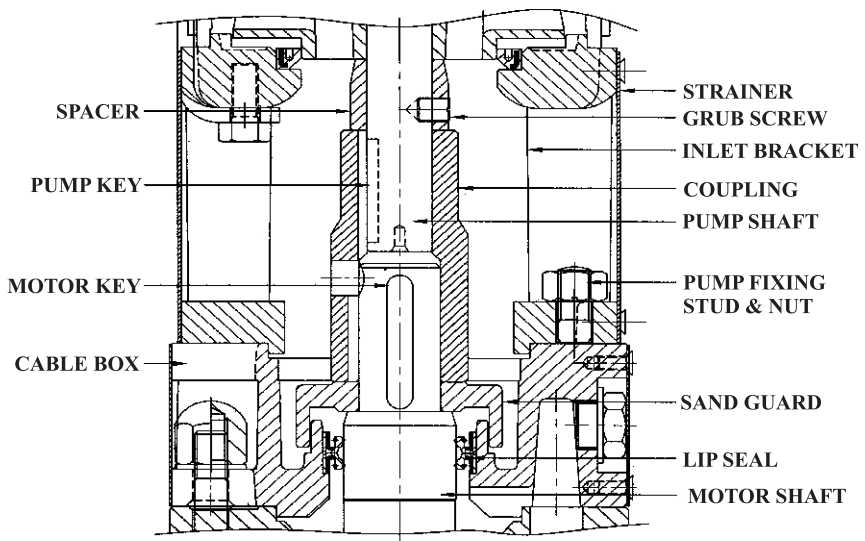

7) Electrical Installation

The motor is supplied with a 3-metre cable. After the water filling of the motor, check the insulation resistance value by a 500 V meggar. It should be more than 20 mega ohms.

Please check the power supply voltage and frequency corresponds to the motor name plate specifications. Observe the relevant ELECTRICITY BOARD regulations while giving power supply to the motor.

a) Switch Gears for Motors

We recommend the use of contactors of sufficient current ratings with no-volt coil and a temperature compensated over-current relay. The use of an ammeter and a voltmeter is also recommended. The instructions provided by the manufacturer for the operation and maintenance of the control panel must be strictly followed.

Our submersible motors are suitable for DOL or STAR-DELTA starting; if these methods are unacceptable, autotransformer type starter with required specifications is to be used.

Phase failure protection can be provided by a PHASE FAILURE RELAY, or an enclosed temperature compensated air break contactor with a thermal over current relay with integral differential trip.

b) Electrical Connection

The cables must be clipped to the pipe up to just above the borewell cover. It should then be laid up to the control panel and connected properly to the starter terminals. The cable must not be coiled if it is of extra length. Any excess should be cut off before the connections are made.

c) Earthing

It is essential to ground the unit to prevent electrical shock. The most convenient point is the delivery pipe at the top of the bore-well. If this is insufficient then the motor casing itself has to be earthed and an extra wire is required for this purpose.

d) Cable Lead Wire Connection to Starter

(i) Direct On Line Starter

Cable	Terminal
Red	Line 1
Yellow	Line 2
Blue	Line 3

(ii) Star Delta Starter

Cable	Terminal
Red	A1
Yellow	B1
Blue	C1

Cable	Terminal
Red	A2
Yellow	B2
Blue	C2

e) Cable Selection

Refer the CHART – 1 for the selection of cables from panel to motor.

CABLE SELECTION CHART

SUBMERSIBLE PUMPSET CABLE SELECTION CHART FOR 415 V - THREE PHASE - 50 Hz

HP	LENGTH IN METRES																				
	10	20	30	40	50	60	70	80	90	100	120	140	160	180	200	250	300	350	400	450	500
1.5	1.5	1.5	1.5	1.5	1.5	1.5	1.5	1.5	1.5	1.5	1.5	1.5	1.5	1.5	1.5	1.5	2.5	2.5	2.5	4	4
2	1.5	1.5	1.5	1.5	1.5	1.5	1.5	1.5	1.5	1.5	1.5	1.5	1.5	2.5	2.5	2.5	2.5	4	4	4	4
3	1.5	1.5	1.5	1.5	1.5	1.5	1.5	1.5	1.5	1.5	1.5	2.5	2.5	2.5	2.5	4	4	4	4	6	6
4	1.5	1.5	1.5	1.5	1.5	1.5	1.5	1.5	1.5	2.5	2.5	2.5	2.5	4	4	4	6	6	6	10	10
5	1.5	1.5	1.5	1.5	1.5	1.5	1.5	2.5	2.5	2.5	2.5	2.5	4	4	4	6	6	10	10	10	10
6	1.5	1.5	1.5	1.5	1.5	1.5	2.5	2.5	2.5	2.5	2.5	4	4	4	6	6	10	10	10	10	16
7.5S	2.5	2.5	2.5	2.5	2.5	2.5	2.5	2.5	4	4	4	4	4	6	6	10	10	10	16	16	16
7.5D	1.5	1.5	1.5	1.5	1.5	1.5	1.5	1.5	1.5	1.5	2.5	2.5	2.5	4	4	4	6	6	10	10	10
10	1.5	1.5	1.5	1.5	1.5	1.5	2.5	2.5	2.5	2.5	2.5	4	4	4	6	6	10	10	10	10	16
12.5	2.5	2.5	2.5	2.5	2.5	2.5	2.5	2.5	4	4	4	4	4	6	6	10	10	10	16	16	16
15	2.5	2.5	2.5	2.5	2.5	2.5	2.5	4	4	4	4	4	6	6	10	10	10	16	16	16	16
17.5	4	4	4	4	4	4	4	4	4	4	6	6	6	10	10	10	16	16	16	16	16
20	4	4	4	4	4	4	4	4	4	6	6	10	10	10	10	16	16	16	25	25	25
25	4	4	4	4	4	4	4	4	4	6	6	10	10	10	16	16	16	25	25	25	25
30	6	6	6	6	6	6	6	6	6	6	10	10	10	10	16	16	25	25	25	35	35
40	10	10	10	10	10	10	10	10	10	10	10	16	16	16	25	25	35	35	35	50	50
50	16	16	16	16	16	16	16	16	16	16	16	16	16	25	25	35	35	50	50	50	70
60	25	25	25	25	25	25	25	25	25	25	25	25	25	25	35	35	50	50	50	70	70
70	25	25	25	25	25	25	25	25	25	25	25	25	25	25	35	35	50	50	50	70	70
80	35	35	35	35	35	35	35	35	35	35	35	35	35	35	35	50	50	70	70	95	95

Note: 1. HP 7.5 D and above are STAR / DELTA motors.

2. For STAR DELTA Starting reduce current by $1/\sqrt{3}$ for selecting suitable cable.

For other Voltages the cable size is to be selected as follows :
 Calculated length = (415 + volt) x actual length

Conversion Table:

1 m = 3.28 ft

1 ft = 0.305 m

Example : For a 20 HP motor at 350 volts and 90 metres actual cable length, calculated length=(415 + 350) x 90 = 107 m . The size of the cable to be selected for 107m from the chart is 6mm².

f) Cable Joints

The motor is normally provided with only 3-meter length of the cable. For joining the additional cable length, the following method is recommended to get water-tight cable joint.

The copper conductors of the red wires of the motor cable and the additional length cable are to be spliced with knife. They are to be soldered together and the joint is to be filed to smooth surface without projections. The joint should be wrapped tightly with rubber cushion compound (Virgin rubber compound available in automotive tube and tyre shop). The PVC insulation tape is to be wrapped tightly on the rubber compound. This process is to be repeated twice to give two layers of rubber compound and PVC insulation tape.

The same procedure is to be used for joining other two wires, yellow and blue. After that the three wire joints are to be taped together neatly.

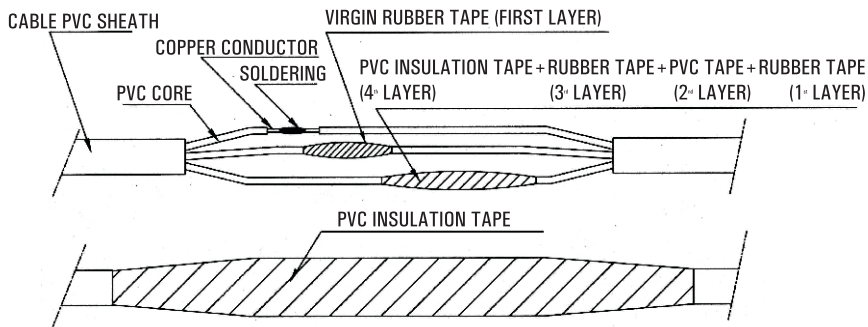

8) Types of Installation

a) Installation in Sandy Area Tube Wells

In sandy area, water table exists at certain depth. Bore well is lined with casing pipes and a slotted strainer pipe at the bottom. In these types of tube wells normally pumpsets are erected at the bottom of the tube well so that pumps operate well below the drawn down level. The set should be installed in such a way that no silt or mud settlement can occur in the region of the motor as this would seriously impair the heat dissipation from the motor and result in winding failure.

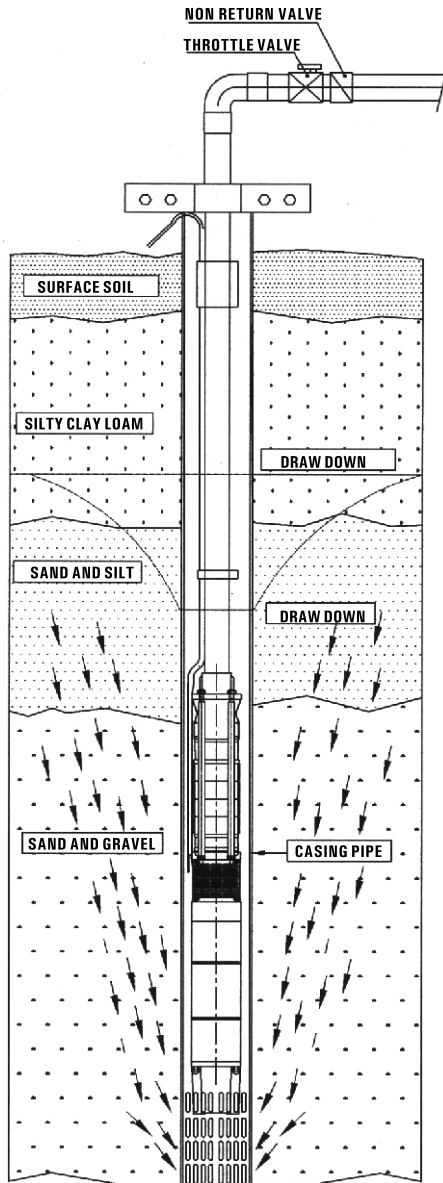

FIG - 5

TUBE WELL IN SANDY AREA

NOTE : PUMPSET TO BE ERECTED ABOVE THE MUD AREA

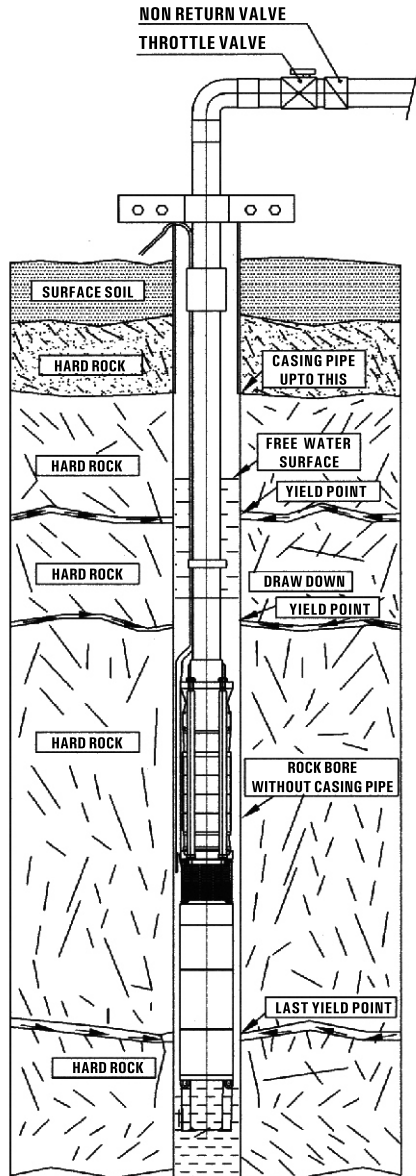

FIG - 6

BORE WELL IN HARD ROCK AREA

NOTE : PUMPSET TO BE ERECTED ABOVE THE LAST YIELD POINT FOR EFFECTIVE COOLING OF MOTOR PORTION.

b) Installation in Hard rock area Bore wells.

In hard rock area borewells, normally water is collected from one or more yield points. The set should be installed just above the last yield point so that the water coming from the last yield point cools the motor surface and enters the pump suction.

9) Operation

a) Excessive Sand in the Water

In a newly bored well the pump must be run at first with the gate valve partially opened. The water is then examined for sand content. If there is a noticeable quantity of sand in the water the pumpset should be run with the gate valve partially opened until the sand content in the water falls to an unnoticeable level. It is important that the pump is not stopped until clear water flows, i.e. it must not be switched off while pumping sandy water.

b) Direction of Rotation

The correct rotation of the pumpset will be indicated by a higher discharge with the gate valve fully opened. The method of setting the correct direction of rotation is as follows.

The pumpset is started and discharge noted. Any two supply leads are inter-changed on the starter and the pump set is run again and the discharge noted. The correct direction of rotation will give a higher discharge.

c) Shut-Down Periods

The pumpset should not remain idle for more than a week since it may lead to jamming of moving parts. If the pumpset is to be remain idle for longer periods it is to be run at least once in every week for five minutes. This will ensure that the pumpset is ready for service at any given time.

d) Operation at Shut-Off

The pumpset should not be run for more than five minutes at zero discharge since the pump will get over heated due to churning of water in the pump.

If a low discharge is required at least 10% of the maximum discharge must be allowed.

e) Switching Frequency

The standstill time of the pump between switching off and switching on again should be of at least five minutes.

SECTIONAL VIEW AND SPARE PART LIST OF 6" SUBMERSIBLE MOTOR (ECON)

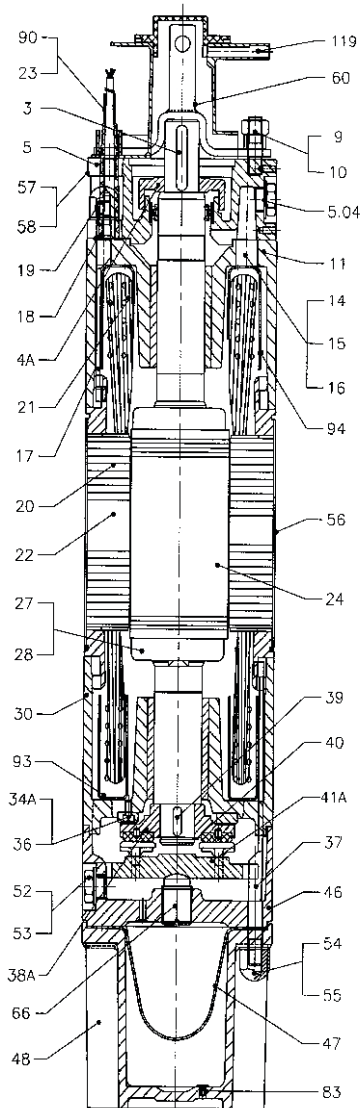

P.No.	PART NAME	QTY.
3	KEY (COUPLING-MOTOR END)	1
4A	SAND GUARD	1
5	CABLE BOX ASSY	1
5.04	DRAIN PLUG - TOP	1
9	STUD (C.BOX)	4
10	NUT (C.BOX)	4
11	TOP BRG. HOUSING ASSY.	1
14	TERMINAL LOCK WASHER	**
15	OVAL WASHER	2
16	TERMINAL DUMMY	***
17	T-BOLT (TOP)	4
18	"O" RING (T-BOLT)	4
19	DOME NUT	4
20	STATOR ASSY.	1
21	WINDING WIRE	-
22	WEDGE	24
23	CABLE	-
24	ROTOR SHAFT ASSY	1
27	BALANCING COLLAR	2
28	H.S. HEAD GRUB SCREW	2
30	BOT.BRG. HOUSING ASSY.	1
34A	THRUST RING	1
36	CH.HEAD SCREW (T.RING)	3
37	T-BOLT (BOT.)	4
38A	THRUST COUPLING ASSY	1
39	KEY (T.COUPLING)	1
40	CIRCLIP	1
41A	THRUST BRG. ASSY.	1
46	BASE (TOP)	1
47	DIAPHRAGM	1
48	BASE (BOT.)	1
52	DRAIN PLUG - BOTTOM	1
53	WASHER (D.PLUG)	1
54	DOME NUT	4
55	WASHER (D.NUT)	4
56	NAME PLATE	1
57	STRAINER	1
58	CSK SCREW	2
60	LIFTING CLAMP	1
66	ROCKER SCREW	1
83	RELIEF PIN	4
90	CABLE SAFETY SLEEVE	S-1, SD-2
93	WINDING COVER - BOT.	1
94	WINDING COVER - TOP	1
119	CABLE HOLDER	1

Note : Part 60, 119 to be removed at the time of Installation.

SECTIONAL VIEW AND SPARE PART LIST OF 6" RADIAL FLOW PUMP (ECON)

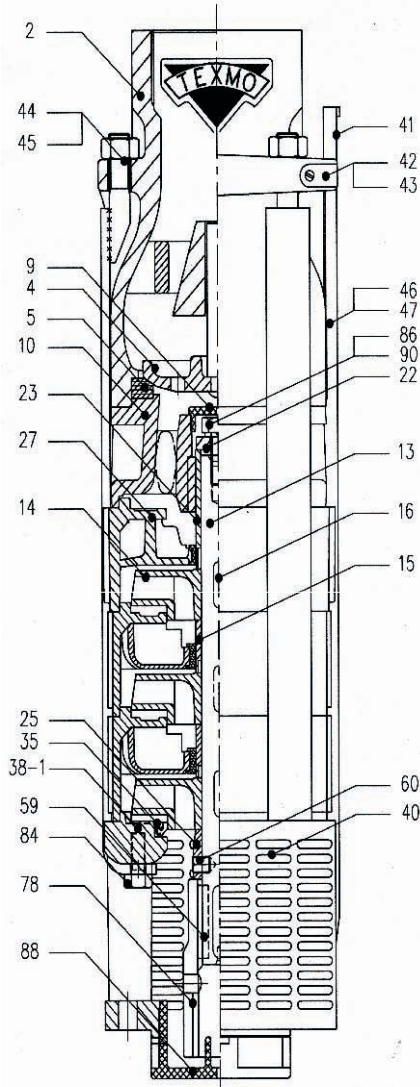

P.No.	PART NAME	QTY.
2	VALVE CASING	1
4	NON RETURN VALVE ASSY	1
5	VALVE SEAT	1
9	DUMMY	1
10	TOP HOUSING ASSY.	1
13	PUMP SHAFT	1
14	IMPELLER	X
15	DISTANCE PIECE	X-1
16	KEY (IMP)	X
22	COLLAR	1
23	SLEEVE (TOP)	1
25	SPACER	1
27	DIFFUSER HOUSING ASSY.	X
35	LIP RING	1
38-1	INLET BRACKET	1
40	STRAINER	1
41	CABLE GUARD	ST=1, SD=2
42	CABLE GUARD CLIP	ST=1, SD=2
43	C.H. CAP SCREW	ST=4, SD=6
44	TIE BOLT ASSY	4
45	NUT (TIE BOLT)	4
46	NAME PLATE	1
47	RIVET (NAME PLATE)	4
59	KEY (PUMP END)	1
60	GRUB SCREW (Spacer)	1
78	COUPLING	1
84	HEX. BOLT	4
86	HEXAGONAL BOLT	1
88	PUMP DUMMY	1
90	SPRING LOCK WASHER	1

X - No. of STAGE

ST - STAR

SD - STAR / DELTA

Note : Part 88 to be removed at the time of Installation.

SECTIONAL VIEW AND SPARE PART LIST OF 6" MIXED FLOW PUMP (ECON)

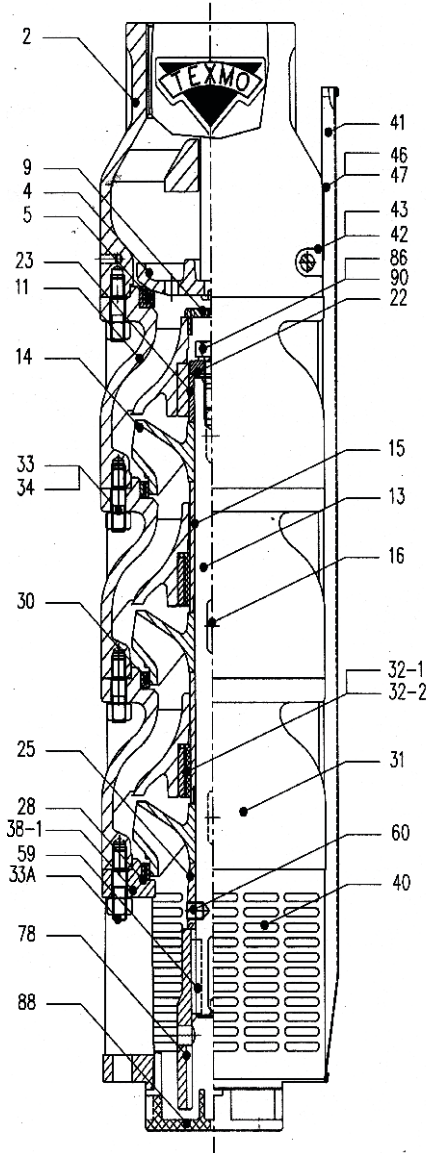

P.No.	PART NAME	QTY.
2	VALVE CASING	1
4	NON RETURN VALVE ASSY	1
5	VALVE SEAT	1
9	DUMMY	1
11	TOP BOWL ASSY.	1
13	PUMP SHAFT	1
14	IMPELLER	X
15	DISTANCE PIECE	X - 1
16	KEY (IMP)	X
22	COLLAR	1
23	SLEEVE (TOP)	1
25	SPACER	1
28	"O" RING	X + 1
30	WEAR RING	X
31	STAGE BOWL	X - 1
32-1	BEARING BUSH - INNER	X - 1
32-2	BEARING BUSH - OUTER	X - 1
33	STUD (Except 1st stage BOWL)	8X
33A	STUD (1st stage BOWL)	8
34	NUT	8X+8
38-1	INLET BRACKET	1
40	STRAINER	1
41	CABLE GUARD	1
42	CABLE GUARD CLIP	1
43	C.H. CAP SCREW	4
46	NAME PLATE	1
47	RIVET (NAME PLATE)	5
59	KEY (PUMP END)	1
60	GRUB SCREW (spacer)	1
78	COUPLING	1
86	HEXAGONAL BOLT	1
88	PUMP DUMMY	1
90	SPRING LOCK WASHER	1

X - No. of STAGES

Note : Part 88 to be removed at the time of Installation.

10) Operating Troubles and the Causes

a) Operating Troubles

Troubles	Possible causes
Pump doesn't deliver water	1, 2 and 3
Pump delivers insufficient water	5, 6, 7 and 8
Total head too low	5 and 6
Absorbed power is excessive.	2, 4, 9 and 11
Pump runs roughly and noisily.	4, 10 and 11

b) Possible Causes

1. Motor doesn't start because no power supply is available (line dead)
2. One defective fuse
3. Pump has been stored under unfavorable conditions for a long period before installation. Consequently the rotor has seized as a result of corrosion and oxidation at the impeller sealing clearance and in the bearings.
4. Pump choked with sand as result of in-rush of sand in to the borehole.
5. Abrasives wear of pump bearings after prolonged operation or due to operation in water of higher sand content or corrosiveness.
6. Change in the actual static head.
7. Discharge pipe rising main coated with depositions from water etc.
8. Foreign bodies lodged in impellers.
9. Voltage is too low
10. Damaged motor radial bearing.
11. Bearings are worn (to be renewed).

WARRANTY FOR SUBMERSIBLE PUMPSET

Aquasub Engineering warrants to the purchaser of this TEXMO product, that for a period of 12 months commencing from the date of purchase of the product, Aquasub Engineering will repair or replace free of charge any part or parts of the product, should Aquasub Engineering be fully satisfied in its sole discretion, that the defect/s is / are due to faulty material or workmanship only. The warranty will be governed by the following clauses:

1. Aquasub Engineering or their Authorised Service Agent / Dealer will repair / replace all parts that are failing due to faulty material or defective workmanship pertaining to the above product.
2. Only Aquasub Engineering or its Authorised Service Agent / Dealer can service / repair or attend to install / reinstall the above product.
3. All expenses incurred in collecting the units or parts thereof from the Authorised Service Centre or the Dealer of Aquasub Engineering as well as expenses incurred in connection with deputing of service personnel / technicians towards to and fro travel conveyance and other incidentals etc., will be borne by the customer.
4. The warranty extended therein is in lieu of all implied conditions and warranties under the law and is confined to the repair or replacement of defective parts and does not cover any consequential or resulting liability, damage or loss arising from such defects. Further more, the warranty in no case, shall extend to the payment or any monetary consideration whatsoever, of the replacement or return of the product as a whole.
5. The warranty is issued subject to jurisdiction of Coimbatore Court of Law.
6. The warranty is covered by Force Majeure clause. In the event if the above product is struck by any natural calamity, this warranty stands null and void.

This Warranty is not valid in case of any of the following events.

- a. This Pumpset is not used according to the instructions given in this Installation and Operation manual.
- b. If the electrical power supply voltage is not within the stipulated norms.
- c. Any repair work / installation carried out by a person other than Aquasub Engineering Service Centre / Service Agent.
- d. The serial Number is deleted, defaced or altered.

WARRANTY CARD

(Please retain this for your personal record)

Product Name & Model No. Serial No.

Name and Address of Dealer

Bill No. Date of Purchase



PUMPS YOU CAN RELY ON



4" 6" 6" 8" 10"
"TEXMO"
SUBMERSIBLE PUMPSETS



"TEXMO"
VERTICAL JET PUMPSET



"TEXMO"
SINGLE PHASE DOMESTIC PUMPSET



"TEXMO"
SUBMERSIBLE MONOBLOCK
PUMPSET



"TEXMO"
SINGLE PHASE SELF PRIMING
MINI MONOBLOCK



"TEXMO"
DOMESTIC PRESSURE
BOOSTING SYSTEM



"AQUATEX"
HYDRO PNEUMATIC SYSTEM



"AQUATEX"
HORIZONTAL MULTISTAGE
STAINLESS STEEL
CENTRIFUGAL MONOBLOCK



"AQUATEX"
OPEN-WELL SUBMERSIBLE
MONOBLOCK



"AQUATEX"
VERTICAL OPEN-WELL
SUBMERSIBLE PUMPSET



"AQUATEX"
AGRICULTURAL / ENDSUCTION
MONOBLOCK



"AQUATEX"
ELECTRIC MOTOR