

**AQUA GROUP**



## **DOMESTIC PRESSURE BOOSTING SYSTEM**

### **ADBS HS Series**



## **INSTALLATION MANUAL**

### **AQUASUB ENGINEERING**

TUDIYALUR POST, COIMBATORE - 641 034

TEL : 0422 - 2642484, E-mail : [marketing@aquagroup.in](mailto:marketing@aquagroup.in)

Website : [www.aquagroup.in](http://www.aquagroup.in)

**AQUA GROUP**



# **DOMESTIC PRESSURE BOOSTER SYSTEM**

## **ADBS HS Series**

### **INSTALLATION MANUAL**

**AQUASUB ENGINEERING**

TUDIYALUR POST, COIMBATORE - 641 034

TEL : 0422 - 2642484, E-mail : [marketing@aquagroup.in](mailto:marketing@aquagroup.in)

Website : [www.aquagroup.in](http://www.aquagroup.in)

## **CONGRATULATIONS**

Dear customer,

Congratulations on your purchase of 'AQUATEX' Domestic pressure booster system. It is a highly efficient pressure boosting system and it is designed and manufactured with stringent quality control to give trouble free service for years.

Please follow the instructions given in this manual to install and maintain 'AQUATEX' Pressure Booster System to get the best and reliable operation .Utilize the service of a technically qualified technician for installation.

Please inform the name plate details i.e. serial number of the pumpset, type of the pumpset, etc when you order spare parts in future.

### **1. DOMESTIC PRESSURE BOOSTER SYSTEM**

'AQUATEX' Domestic Pressure Booster System delivers water with uniform and constant Pressure in all showers, taps and other fittings in Multi storey Buildings, Residential apartments, Hotels, etc.

The pumpset develop pressure and maintain uniform pressure in the pipelines for effective water utilization .The Pressure switch monitors the pressure in the system and it will switch the pumpset on and off automatically based on system demand. The system consists of high quality Pressure tank, Pressure switch, Pressure gauge, 5 Way Connector and Non Return Valve.

They can be easily fitted at the site as shown in the General assembly Drawing (Refer Fig-1.1)

### **2.HORIZONTAL MULTISTAGE STAINLESS STEEL CENTRIFUGAL MONOBLOCK PUMPSET-AHS Series**

The ADBS-HS Pressure Booster system is fitted with AHS Series- Horizontal Multistage stainless steel centrifugal monoblock Pumpset. The impellers, diffusers and shaft are made of highly corrosion resistant stainless steel. The Pumpset is powered by AC Induction Motor with 'F' Class Insulation, suitable for continuous duty. The motor is of TEFC type and has built-in Thermal Overload Protector. For spare parts details please refer Exploded view (Fig 17.1) and Spare parts list (Fig 17.2) of AHS Series pumpset.

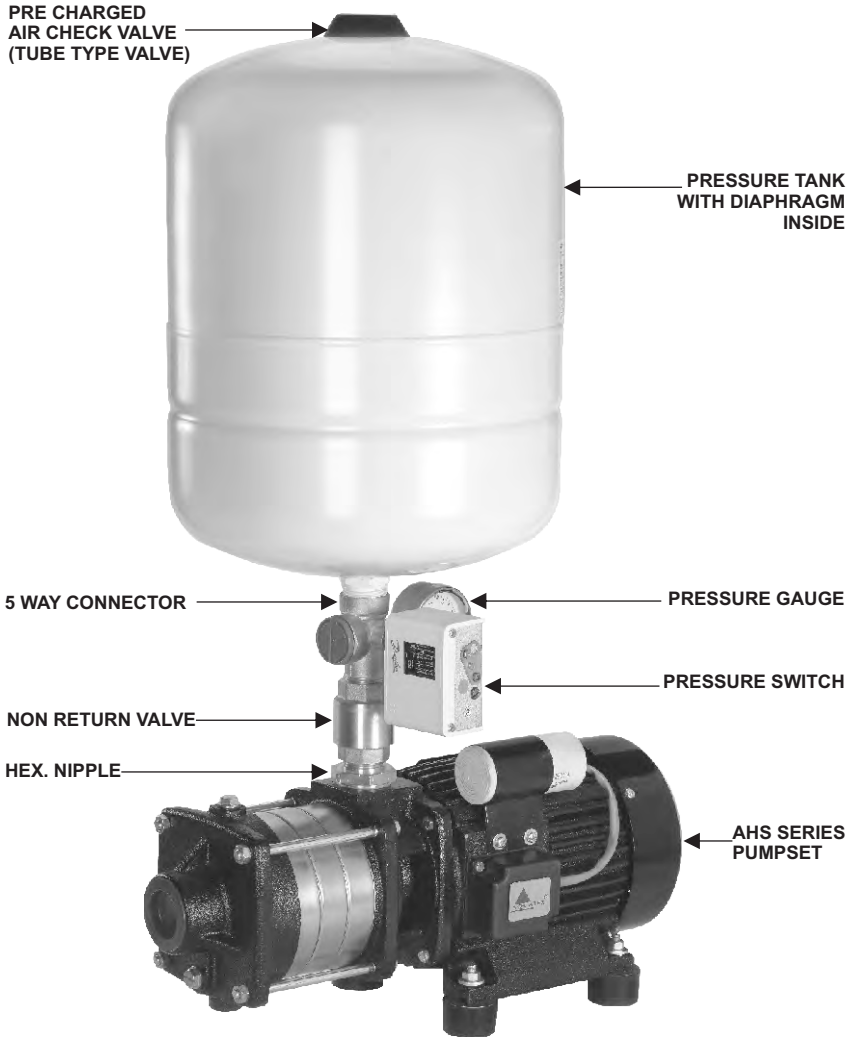

Fig - 1-1

General Assembly Drawing of ADBS-HS Series Domestic Pressure Booster System

### 3. PRESSURE TANK

Pressure tank is used as a storage device for pressurized water. It prevents frequent starting and stopping of pumpset and acts as a buffer. Pressure tank is constructed of virgin polypropylene liner combined with a high grade butyl diaphragm. The diaphragm is held against the wall of the tank with a steel clench ring .The brass air valve seal prevents air leakage at top. Water enters the tank through a stainless steel water connection at bottom.

The water and air seal inside the tank, during operation, ensures a complete leak free and maintenance free pressure vessel.



**Do not set pre charge air pressure in tank beyond cut-in pressure (Pumpset start pressure)**

Improper installation may result in tank explosion in the event of a system malfunction, resulting in property damage.

### 4. PRESSURE SWITCH

Pressure Switch is used to control pressure limits in Domestic Pressure Boosting System. The pressure switch is fitted with single-pole changeover switch (SPDT).It consists of snap action contact system and bellow which moves only when cut-in(pumpset start) or cut-out(pumpset off) point is reached. Because of snap action function, the cut-out (pumpset off) point of the pressure switch control remains very accurate and completely independent of the magnitude of the current load.

The cut out and differential pressure scale range can be preset in the pressure switch. The pressure switch ensures the required pressure in the piping system and keeps the pressure always within the preset level.

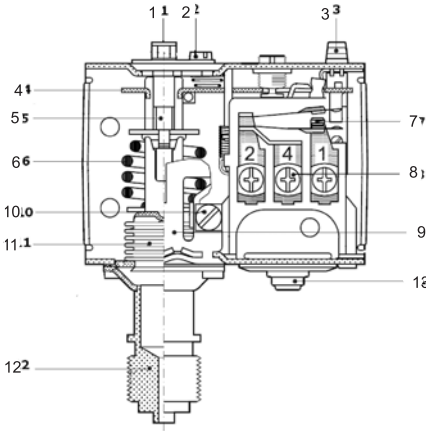

**Fig-4.1 PRESSURE SWITCH**

1. Cut out (pumpset off) scale nut
2. Differential scale nut
3. Spring tension adjustment knob
4. Main arm
5. Range setting spindle
6. Main spring
7. Snap contact system
8. Control terminals (4, 2, and 1)
9. Distance plate
10. Earth terminal
11. Bellow
12. Pressure connector
13. Cable entry: 1/2" Female cable gland

## 5. PRESSURE GAUGE

It is a Bourdon type pressure gauge which consists of sensing element made up of curved metal tube flattened in cross section and closed. It is used for setting purpose and pressure monitoring in the delivery pipe line.

## 6. '5' WAY CONNECTOR

A high quality forged Brass '5' way connector which consists of 5 ports, two are 1" inside thread, one is 1" outside thread, and two are 1/4" inside thread. It is used for connecting Pumpset, Pressure tank, Pressure switch, Pressure Gauge, Non return Valve and Delivery Pipe.

## 7. ASSEMBLY OF DOMESTIC PRESSURE BOOSTER SYSTEM

The system is preconfigured and tested at factory. Normally the system is despatched with components in dismantled condition. Please follow the procedure to assemble the system. Study the General Assembly drawing (Fig-1.1) before startup.

### Step-1

Connect NRV bottom Side (observe arrow symbol towards top) with 1"x1¼" Nipple (Fig-7.1)

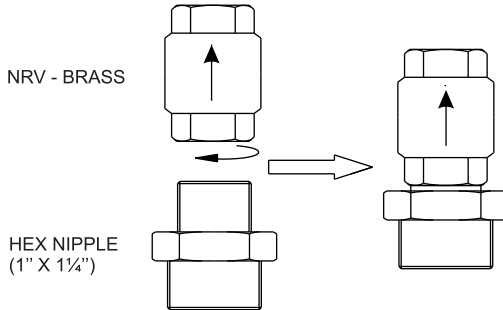

**Fig-7.1**

### Step-2

Tighten 5 way connector (out side thread side) with top side of NRV (Fig-7.2)

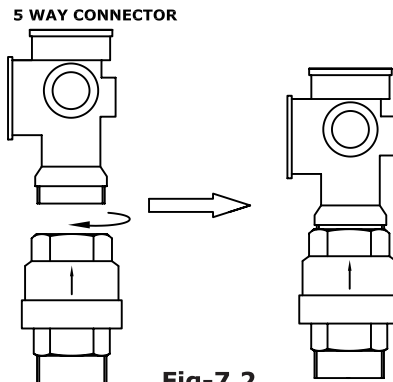

**Fig-7.2**

**Step-3**

Connect the pressure switch with the 5 way connector's ¼ "BSP inside thread side (Fig-7.3)

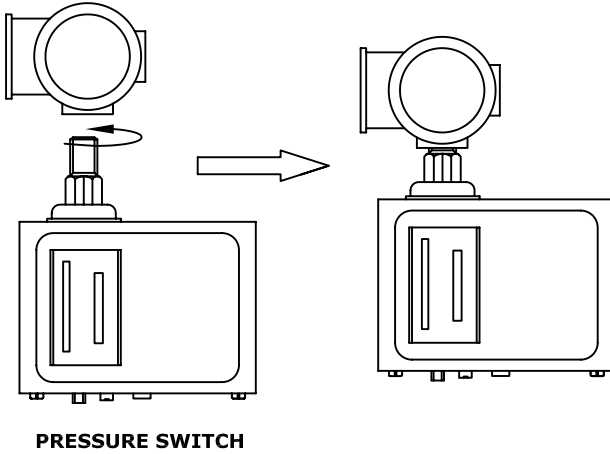

**Fig-7.3 ASSEMBLY TOP VIEW**

**Step-4**

Connect the pressure gauge with the 5 way connector's ¼ "BSP inside thread side (Fig-7.4)

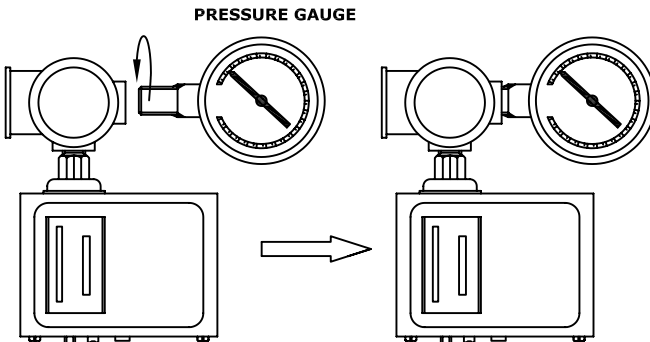
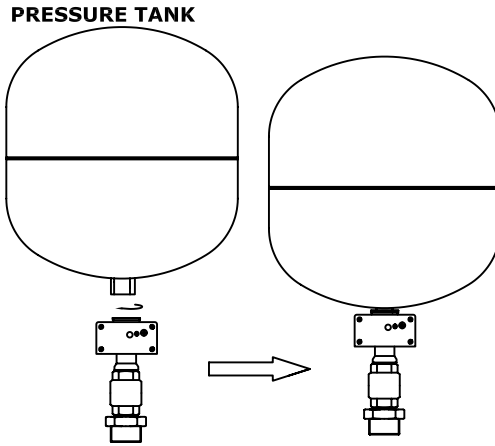

**Fig-7.4 ASSEMBLY TOP VIEW**



**Step-5**

Fix the pressure tank at top of the 5 way connector (Refer Fig-7.5)



**Fig-7.5 ASSEMBLY FRONT VIEW**

**Step-6**

Whole setup is to be fixed at the delivery port of pumpset and finally delivery pipe to be connected with the 5 way connector (Refer Fig-7.6)

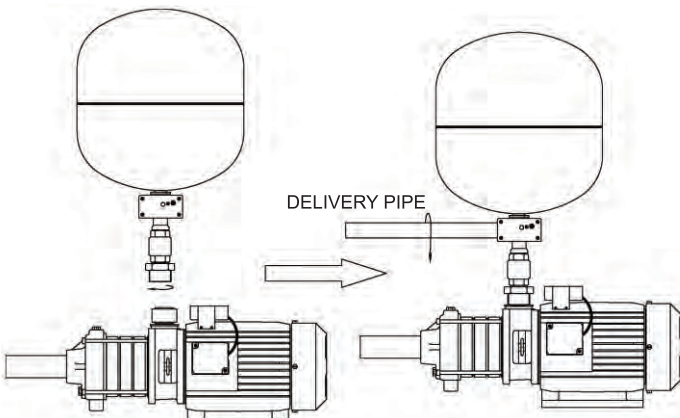

**FIG-7.6 ASSEMBLY CONNECTED TO PUMPSET**

**DELIVERY PIPE CONNECTED TO ASSEMBLY**

## Step-7

In higher capacity pressure tanks (above 60 Liters) mount is provided at the bottom of tank. separate pipe connection is to be made with 5 way connector. Provide a suitable base to rise pressure tank up to the level of 5 way connector to reduce of number of bends and elbows for pressurized water supply (Fig-7.7)

- 01 - Suction Pipe
- 02 - Delivery Pipe
- 03 - Extension (Nipple-1")
- 04 - Union (1")
- 05 - Concrete bas
- 06 - Pressure Tank

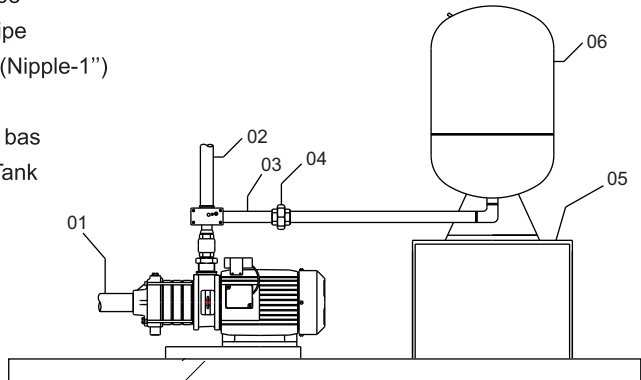

*Assembly with Higher Capacity Pressure Tank*

**Fig-7.7**

## 8.ELECTRICAL CONNECTION



***Observe the relevant ELECTRICITY BOARD regulations while giving power supply to the pumpset.***

- Proper cable size is to be used based on the rating of pumpset.
- The pumpset should be properly earthed to avoid electric shock.
- The direction of rotation of pumpset (when viewed from cooling fan side) is counter clockwise and it should be ensured.
- The power supply voltage and frequency given in the pumpset name plate specification are to be checked.

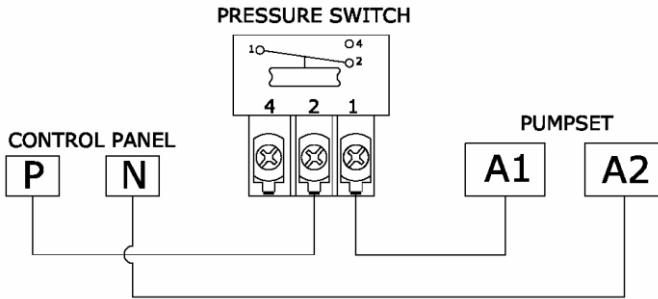

Fig-8.1 ELECTRICAL CIRCUIT CONNECTION DIAGRAM

### 8.1. For Pressure Switch Connection

- Remove front Cover of Pressure switch as shown in Fig-4. 1
- Make Connection between Terminal 1 of Pressure switch with A1 Terminal of the Pump set through Cable gland.
- Make connection between Terminal 2 of the Pressure switch with the Power terminal (P) of Control Panel.
- Connect Neutral Terminal (N) of Control Panel with A2 Terminal of the Pump set.
- Connection are Shown in Electrical Circuit Connection Diagram (Fig. 8-1)

## 9. PRESSURE SWITCH SETTING

Pressure Setting is to be done as per requirement and Pressure setting adjustment can be done in running condition of the pumpset.

1. Cut in Pressure (Pumpset start): It is the pressure of the system at which pumpset should start. It is the terminal pressure required at the outlet plus friction losses of the system. Cut in pressure is to be maintained at or above 1.5 bar. Cut in pressure depends on the head range of pumpset, Pressure tank capacity and discharge of the pumpset.
2. Cut out Pressure (Pumpset off) : It is the pressure of the system at which the pumpset should stop. Cut out pressure must be within (or) at Duty point Head of the selected pumpset.
3. Differential Pressure scale value:  
It is Cut out Pressure value Minus Cut in Pressure value

4. In the Pressure switch, two pressure settings are done.  
One is Cut out Pressure of the system. It should be set in the 'RANGE' scale mentioned in the pressure switch. The difference between cut out pressure and cut in pressure should be minimum of 0.7 bar.

**For example**

**Pressure requirement at outlets: Minimum 1.5 bar (1.5 Kg/Cm<sup>2</sup>)**

**Then the pumpset is to be started at 1.5 bar i.e. Cut in Pressure.**

**Cut out Pressure is to be minimum  
Cut in Pressure in bar + 0.7 bar**

**In our example cut out pressure is  
1.5 bar + 0.7 bar = 2.2 bar.  
So 2.2 bar is to be set in "Range" scale.**

5. Next scale in the pressure switch is Differential Pressure Scale Value.

Differential pressure value is Cut out Pressure Minus Cut in Pressure  
 $2.2 \text{ bar} - 1.5 \text{ bar} = 0.7 \text{ bar}$   
Set 0.7 bar in 'DIFF' scale in the Pressure switch.

6. For setting Range (Cut out Pressure) and Differential Pressure adjust the screws at the top of Pressure switch.
7. Scale in the pressure switch is indicative only. Cut in pressure and cut out pressure should be checked with the readings in accurate Pressure gauge.

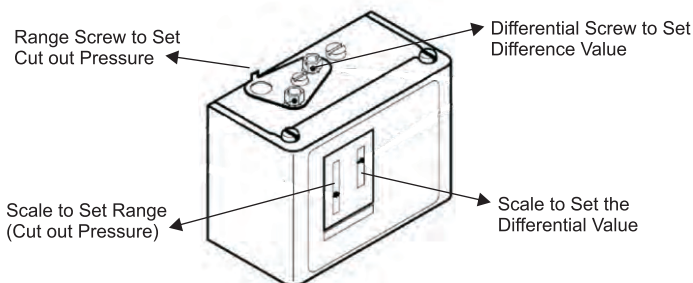

**Fig-9.1**

Use Star Screw driver to Set Cut out Pressure

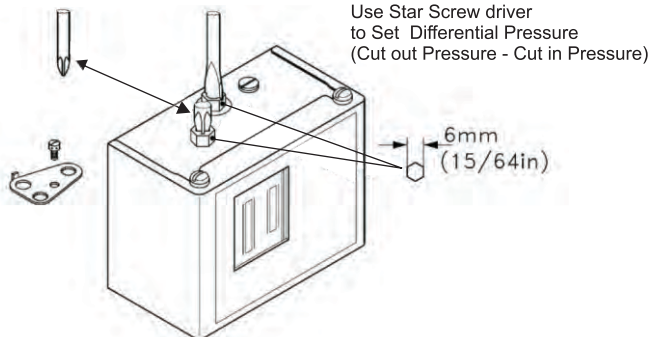

**Fig-9.1**

## 10. PRESSURE TANK SETTING

1. Check pre-charge air pressure in pressure tank with ordinary tyre gauge before starting the pumpset .
2. **Check factory pre-charged air pressure in pressure tank. It should be less than cut in (pumpset start) pressure.**
3. **For example**  
*If cut in pressure is 1.5 bar*  
*Then Pressure tank pre-charged air is to be set at 1.3 bar*
4. Pressure tank should be installed vertical on the pumpset as per assembly drawing for ideal operations.

## 11. INSTALLATION

- The pumpset should be erected in a place relatively free from dust, fumes and moisture
- Sufficient ventilation space should be given at cooling cover side of the motor
- The vertical distance between the water level at the suction side and the pumpset should not exceed 20 feet (6 meters)
- Only recommended pipe size should be used. smaller size pipe, nipple elbows, and bends will give rise to pressure losses and they should either be eliminated or used sparingly
- Use suitable vibration mounting pads at the base of the pumpset to reduce vibration.

## 12. PRIMING OF PUMPSET

Since the pumpset is of non-self priming type, it should be primed before running the system. If the suction head is positive no priming is needed. For negative suction head the following procedure should be adopted for priming

- Before priming, close the ball valve properly in the delivery side.
- Clear cold water is to be filled through priming plug provided at the top of suction bracket and tighten the priming plug properly.
- Do not start the system until the pumpset is completely filled with clear cold water.



A good Quality **FOOT VALVE** and **FILTERS** are to be used in the suction pipeline to avoid priming problems.

## 12. POWER SUPPLY

Power supply plays vital role in automatic operation of pressure booster system. It is recommended to install a suitable power generator to get continuous power supply for automatic operation of the system

## 14. OPERATION OF THE SYSTEM

It is an automatic operating system. It automatically starts and stops according to the demand of water supply in pipe lines. The system operates based on the pressure switch and pressure tank setting. The system operates continuously at demand and stop automatically at no demand.

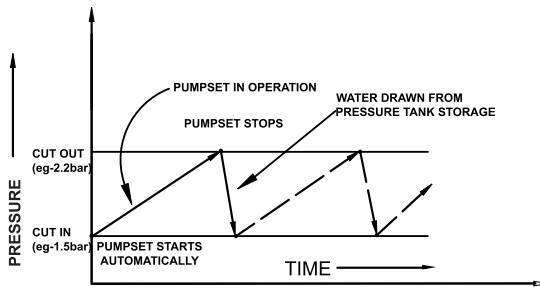
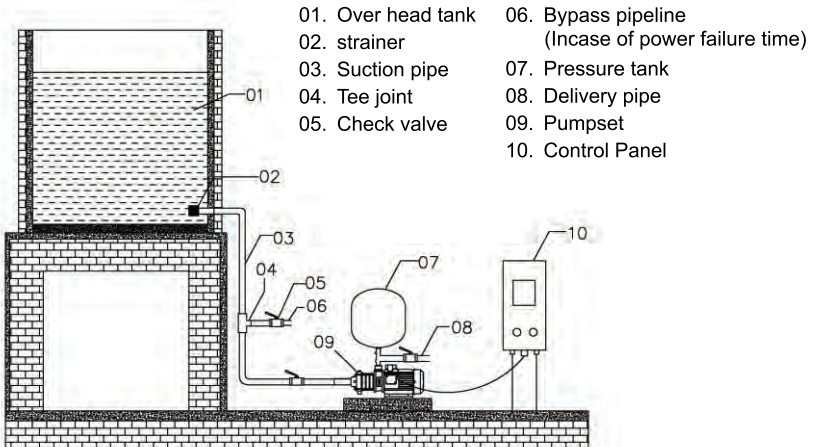

**Fig-13. SYSTEM OPERATION**

## 15. TYPES OF INSTALLATION

### 15.1. Pumpset installation with positive suction head

The pumpset should be installed as shown in the Fig: 14.1.1 for trouble free operation. Provide separate bypass connection at suction pipe line for drawing water from the over head tank directly in case of power failure.



**Fig-15.1** Installation of the system at the Roof Top with positive suction head.

## 15.2. Pumpset installation with negative suction head (suction lift)

Generally avoid installation with negative suction head. If the pumpset is to be installed with negative suction head good quality foot valve is to be used.

The pumpset should be installed as shown in the Fig: 14.2.1 for trouble free operation

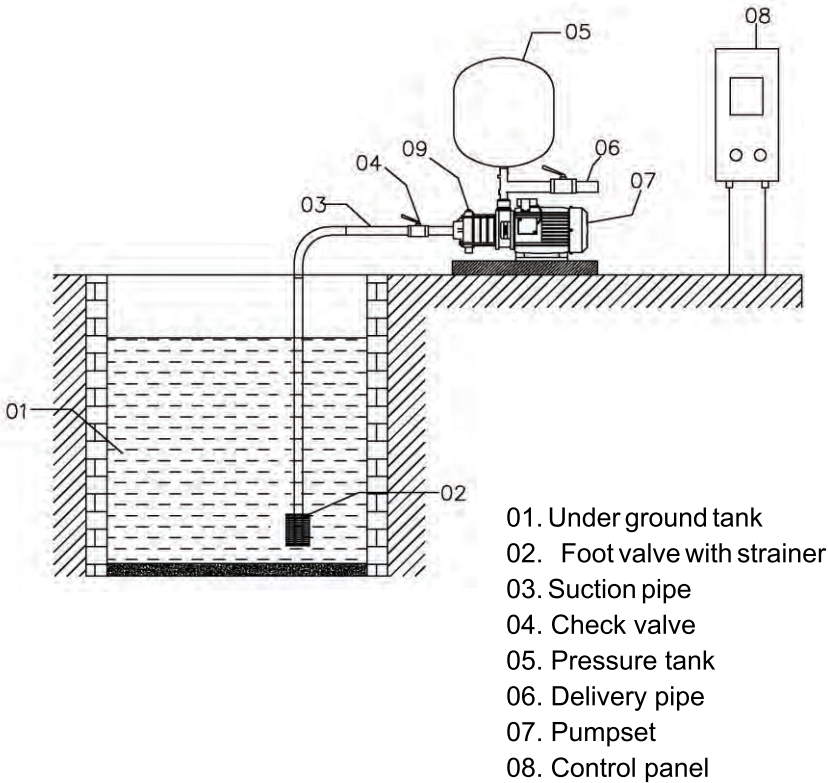

Fig-15.2. Installation of the system at ground level sump with negative suction head



A good Quality **FOOT VALVE** and **FILTERS** are to be used, Incase of failure of foot valve, mechanical seal will fail.



## 16. TROUBLE SHOOTING CHART

<b>S. NO</b>	<b>Troubles</b>	<b>Causes</b>	<b>Remedies</b>
1.	Pumpset delivers insufficient water.	<ul style="list-style-type: none"> <li>• Foreign particles entered in impellers</li> <li>• Pumpset choked with sand and sediments due to in-rush of sand from the tank/sump.</li> <li>• Improper installation Oxidation of impeller clearance</li> <li>• Increase in actual suction head</li> </ul>	<ul style="list-style-type: none"> <li>• Clean the impellers</li> <li>• Clean entire pumpset</li> <li>• Check installation</li> <li>• Fit good quality Strainer</li> </ul>
2.	Pumpset runs roughly, noisily and absorbs excess power	<ul style="list-style-type: none"> <li>• Pump and motor bearings are worn out</li> </ul>	<ul style="list-style-type: none"> <li>• Bearings are to be replaced in pump and motor</li> </ul>
3.	Water leakage observed	<ul style="list-style-type: none"> <li>• Improper fitment of pipes.</li> <li>• Mechanical seal damaged</li> </ul>	<ul style="list-style-type: none"> <li>• Use anaerobic pipe sealant or teflon tape in pipe joints</li> <li>• Mechanical seal assembly to be replaced</li> </ul>
4.	Pumpset doesn't deliver water	<ul style="list-style-type: none"> <li>• Motor coil short circuit</li> <li>• Foreign bodies in casing</li> <li>• Air lock due to foot valve leakages</li> </ul>	<ul style="list-style-type: none"> <li>• Rewind the motor.</li> <li>• Casing is to be cleaned.</li> <li>• Priming is to be done</li> <li>• Foot valve is to be changed.</li> </ul>
5.	Pumpset runs continuously , without Cut Out even at no demand time	<ul style="list-style-type: none"> <li>• Due to high Cut Out (pumpset off) pressure setting in pressure switch, (greater than pumpset duty head)</li> </ul>	<ul style="list-style-type: none"> <li>• Maintain Cut Out (pumpset off) pressure within head range of pumpset</li> </ul>

S. NO	Troubles	Causes	Remedies
6.	Chattering in Pressure Switch	<ul style="list-style-type: none"> <li>• Due to high voltage</li> <li>• Low differential scale value is set in pressure switch</li> </ul>	<ul style="list-style-type: none"> <li>• Regulate power supply</li> <li>• Increase the differential value</li> </ul>
7.	Improper Pressure Switch operation	<ul style="list-style-type: none"> <li>• Spring gets rusted</li> <li>• Foreign particles damages bellow in the switch</li> <li>• Failure in contact systems</li> <li>• Heavy vibration and shocks</li> </ul>	<ul style="list-style-type: none"> <li>• Protect the spring from water</li> <li>• Water to be free from dust and other particles which causes damages.</li> <li>• Reduce vibration by mounting pads at the base of pumpset</li> </ul>
8.	Improper Pressure Switch operation.	<ul style="list-style-type: none"> <li>• Foreign particles damages rubber diaphragm in tank or presence of it in the tank</li> <li>• Due to improper pre charge air pressure setting in tank</li> <li>• Improper plumbing and assembly</li> <li>• Tank gets damaged on outer side</li> </ul>	<ul style="list-style-type: none"> <li>• water to be free from dust and other particles which causes damages</li> <li>• Air should be checked periodically in the pressure tank and it is to be recharged if it is less</li> <li>• Suitable pipes and Teflon seal to be used</li> <li>• Protect the tank to prevent damages.</li> </ul>
9.	Low pressure in pipe lines	<ul style="list-style-type: none"> <li>• Cut in (pumpset start) pressure is less than factory pre charged air pressure in pressure tank</li> </ul>	<ul style="list-style-type: none"> <li>• Cut in (pumpset start) pressure should be higher than pre charged air pressure in tank.</li> </ul>

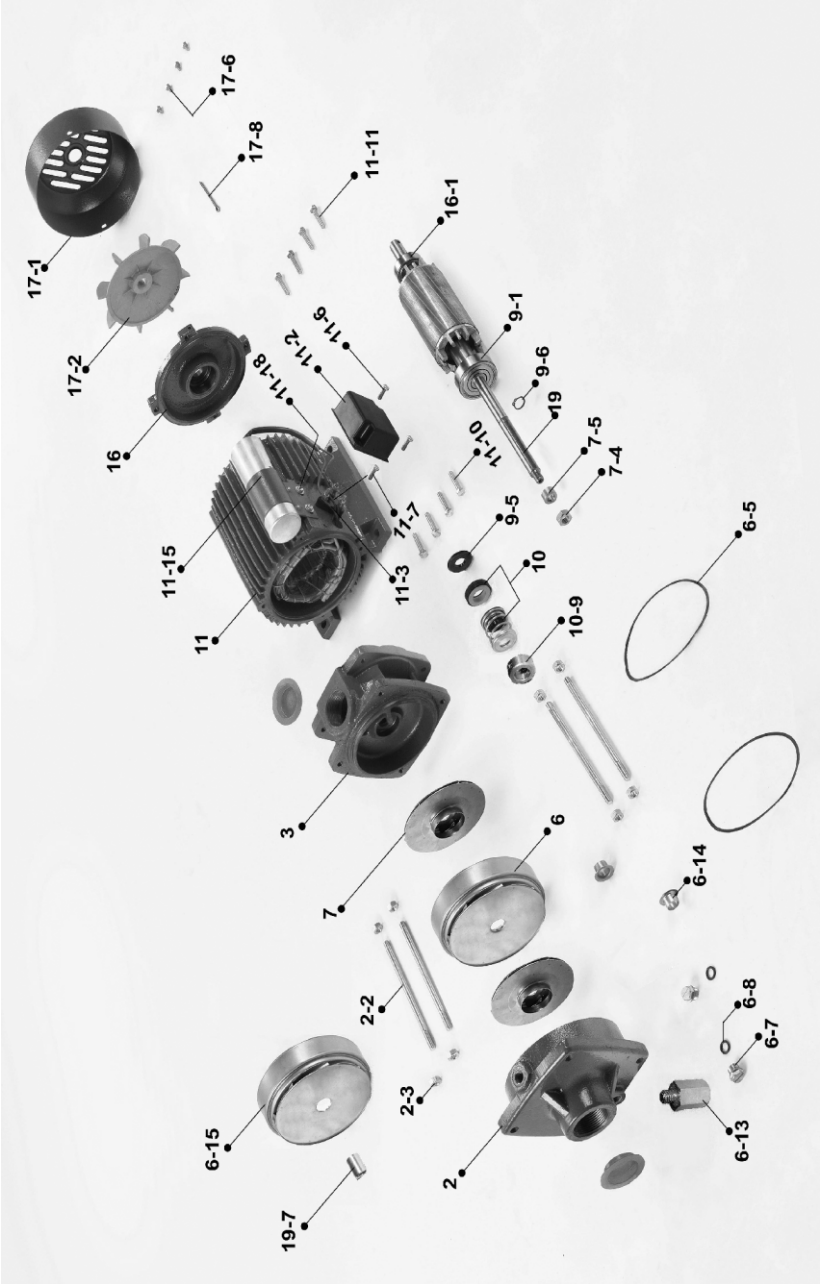

Fig 17.1 Exploded view of AHS Series pumpset

PART NUMBER	PART NAME	QUANTITY	MATERIAL	9-6	CIRCLIP	1	SP-STEEL
2	SUCTION BRACKET	1	CAST IRON	10	MECHANICAL SEAL ASSY	1	-
2-2	TIE ROD	4	MS (ZINC COATED)	10-9	SEAL LOCKING COLLAR	1	SS, AISI 410
2-3	TIE ROD NUT	8	MS (ZINC COATED)	11	STATOR FRAME	1	-
3	DELIVERY BRACKET	1	CAST IRON	11-2	TERMINAL BOX COVER	1	PLASTIC
6	STAGE CASING	STAGE - (Up to 4 Stages)	SS, AISI 304	11-3	TERMINAL BOARD	1	BAKELITE
6-5	STAGE CASING GASKET	1/Stage	LEATHEROID PAPER	11-6	TERMINAL BOX COVER SCREW	2	MS (ZINC COATED)
6-7	DRAIN PLUG	2	BRASS	11-7	TERMINAL BOARD SCREW	1	MS (ZINC COATED)
6-8	DRAIN PLUG O'RING	2	NITRILE RUBBER	11-10	DEL BRAC & FRAME HEX BOLT	4	MS (ZINC COATED)
6-13	SUCTION BRACKET LEG SUPPORT	1 (for 1.5 & 2 HP)	MS (ZINC COATED)	11-11	BACK COVER & MOTOR FRAME HEXAGONAL BOLT	4	MS (ZINC COATED)
6-14	SPACER	(STAGE x 2) - 2 (Up to 4 Stages)	SS, AISI 410	11-15	CAPACTOR WITH CLAMP	1 (for 0.5 & 1 HP) 2 (for 1.5 & 2 HP)	-
6-15	BUSH STAGE CASING	(STAGE x 2) - 4 (6 Stages & above)	SS, AISI 304	11-18	CAPACTOR CLAMP SCREW	2	MS (ZINC COATED)
7	IMPELLER	1 (Only for 6 Stages & above)	SS, AISI 304	16	BACK COVER	1	CAST IRON
7-4	IMPELLER LOCK NUT	1/Stage	SS, AISI 304	16-1	BACK BEARING	1	SS
7-5	LOCK SLEEVE	2	SS, AISI 410	17-1	COOLING COVER	1	MS
9-1	FRONT BEARING	1	SS, AISI 410	17-2	COOLING FAN	1	PLASTIC
9-5	WATER CUTTING RING	1	NITRILE RUBBER	17-6	COOLING COVER SCREW	4	MS (ZINC COATED)
				17-8	SPLIT PIN FOR COOLING FAN	1	SS
				19	ROTOR SHAFT ASSEMBLY	1	SS, AISI 410
				19-7	BUSH SLEEVE	1 (Only for 6 Stages & above)	SS, AISI 304

Fig 17.2 Spare parts list of AHS Series pumpset

# AQUA GROUP

## BRANCH OFFICES & PHONE NUMBERS

### TAMILNADU

COIMBATORE	(0422)	2642572
MADURAI	(0452)	2530002
CHENNAI	(044)	26493919

### KERALA

TRICHUR	(0487)	2374004
---------	--------	---------

### KARNATAKA

BENGALURU	(080)	23381891
HUBLI	(0836)	2355729

### TELENGANA

SECUNDERABAD	(040)	27903381
--------------	-------	----------

### SEEMANDHRA

VIJAYAWADA	(0866)	2578807
CHITTOOR	(08572)	226338

### MAHARASHTRA

MUMBAI	(022)	32536113
PUNE	(020)	60124765
NAGPUR	(0712)	2547082

### MADHYA PRADESH

INDORE	(0731)	4037630
--------	--------	---------

### CHATTISGARH

RAIPUR	(0771)	2443144
--------	--------	---------

### GUJARAT

AHMEDABAD	(02718)	261179
-----------	---------	--------

### RAJASTHAN

JAIPUR	(0141)	2291533
--------	--------	---------

### PUNJAB & HARYANA

PANCHKULA	(0172)	3242903
-----------	--------	---------

### WEST BENGAL

KOLKATTA	(033)	25463228
----------	-------	----------

### BIHAR

PATNA	(0612)	2344225
-------	--------	---------

### UTTAR PRADESH

KANPUR	(0512)	2655028
GHAZIABAD	(0120)	4131288

### EXCLUSIVE DISTRIBUTOR

BHUBANESHWAR	(0674)	2546725
--------------	--------	---------

# AQUA GROUP

Pumps you can rely on



Borewell Submersibles  
Single Phase Jet Pumps  
Single Phase Domestic Pumps



Openwell Submersibles  
Agricultural Monoblocks  
Pressure Boosting Systems

# AQUASUB ENGINEERING AQUAPUMP INDUSTRIES



**PUMPS YOU CAN RELY ON**



4" 6" 6" 8" 10"  
"TEXMO"  
SUBMERSIBLE PUMPSETS



"TEXMO"  
VERTICAL JET PUMPSET



"TEXMO"  
SINGLE PHASE DOMESTIC PUMPSET



"TEXMO"  
SUBMERSIBLE MONOBLOCK  
PUMPSET



"TEXMO"  
SINGLE PHASE SELF PRIMING  
MINI MONOBLOCK



"TEXMO"  
DOMESTIC PRESSURE  
BOOSTING SYSTEM



"AQUATEX"  
HYDRO PNEUMATIC SYSTEM



"AQUATEX"  
HORIZONTAL MULTISTAGE  
STAINLESS STEEL  
CENTRIFUGAL MONOBLOCK



"AQUATEX"  
OPEN-WELL SUBMERSIBLE  
MONOBLOCK



"AQUATEX"  
VERTICAL OPEN-WELL  
SUBMERSIBLE PUMPSET



"AQUATEX"  
AGRICULTURAL / ENDSUCTION  
MONOBLOCK



"AQUATEX"  
ELECTRIC MOTOR

® Registered Trademark of Aquasub Engineering & Aquapump Industries for products listed.